

2600mm dia. Ocean Buoy

TRIDENT-2600

Sealite have a range of mooring chains & accessories - ask your representative today how we can supply your complete mooring solution



Environmentally Friendly & Recyclable

Sealite buoy products are made from recyclable materials. As a service to customers, individual components and products at the end of their service life may be returned to Sealite for recycling.



The TRIDENT-2600 is one of the largest rotationally-moulded buoys available, with a float diameter of 2.6 meters and lantern focal height of up to 5 meters.

The float section of the TRIDENT-2600 is built from four (4) rotationally-moulded quadrants, which fasten together to form an incredibly robust 2.6 meter wide float section standing 1.5 meters tall. Each quadrant is moulded from UV-stabilised, virgin polyethylene, and has an 18mm wall thickness. In addition, each section may be filled with closed-cell polyurethane, which prevents the ingress of moisture in the unlikely event of damage.

The enhanced poly-tower design provides a huge visual area for navaid recognition, and consists of a sealed, rotationally-moulded tower section. The tower incorporates an internal radar reflector and solar mount facility.

Rotationally moulded daymarks are fitted to the outside of the tower to create a large daymark shape for Lateral Marks. Replaceable daymarks give the operator flexibility in stocking spares.

A steel mooring post runs through the centre of the assembly, to which the tower section is fastened. An integrated ladder with harness attachment points runs vertically up the tower to the top of the platform and two large lifting eyes aid in buoy mooring and periodic servicing.

The unique design of the mooring post and flat base means the buoy can be stored upright in service yards and transported via truck and service vessels for increased handling safety.

No part of the structure requires painting at any stage of the product's life span.

A large counterweight offers exceptional stability in a variety of exposed regions.

The TRIDENT-2600 can be supplied in all IALA colours.

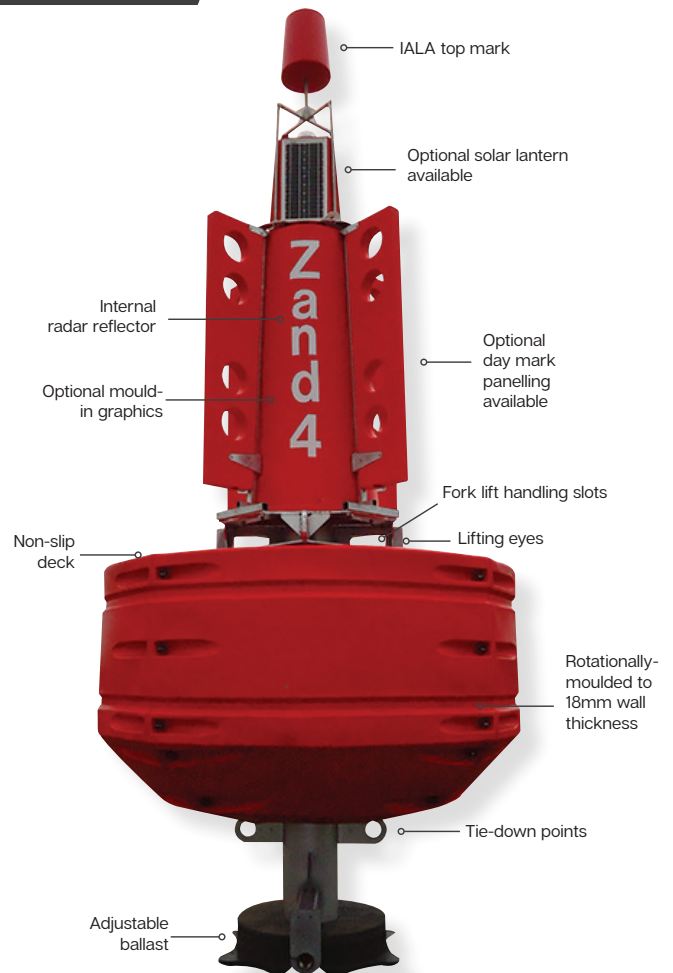

The Sealite Advantage

- High visibility red, green, white or yellow as per IALA recommendations
- Robust construction of 4 quadrant hull sections
- Lightweight
- Excellent buoyancy & stability
- Easy to deploy & service
- No painting, ever
- Stands flat on service vessel deck
- Cost effective & environmentally friendly
- Convenient forklift access points to safely manoeuvre the buoy assembly

Technical Specifications.*

	TRIDENT-2600	TRIDENT-2600-C
	Standard Model	Compact Model
General Characteristics		
Available Colours	Red, Green, White, Yellow as per IALA Recommendations	Red, Green, White, Yellow as per IALA Recommendations
Focal Plane Height (mm/inches)	4025 / 158 $\frac{1}{2}$	3825 / 150 $\frac{1}{2}$
Total Float Volume (ltrs/US gallon)	6710 / 1772	6710 / 1772
Nominal Freeboard (mm/inches)	865 / 34	865 / 34
Nominal Draft (mm/inches)	1325 / 52 $\frac{1}{2}$	1325 / 52 $\frac{1}{2}$
Total Reserve Buoyancy (kgs/lbs)	4538 / 10004	4538 / 10004
Operational Buoyancy (kgs/lbs)	2000 / 4409	2000 / 4409
Maximum Mooring Load (kgs/lbs)	2000 / 4409	2000 / 4409
Draft, Maximum (mm/inches)	1690 / 66 $\frac{1}{2}$	1690 / 66 $\frac{1}{2}$
Freeboard, Minimum (mm/inches)	500 / 19 $\frac{1}{2}$	500 / 19 $\frac{1}{2}$
Safe Working Load, 1pt (kgs/lbs)	5500 / 12125 (one lifting point)	5500 / 12125 (one lifting point)
Safe Working Load, 2pt (kgs/lbs)	11000 / 24250 (two lifting points)	11000 / 24250 (two lifting points)
Submergence (kg/cm, lb/inches)	54.7 / 306	54.7 / 306
Visual Area (m²/ft²)	4.7 / 50.6 (without daymark) 6.0 / 64.5 (with daymark)	4.3 / 46.3 (without daymark) 5.6 / 60.2 (with daymark)
Water Area (m²/ft²)	1.7 / 18.3	1.7 / 18.3
Physical Characteristics		
Material	Rotationally-moulded UV-stabilised virgin polyethylene float section, tower assembly, top marks and panelling. 316-grade stainless steel fixtures.	Rotationally-moulded UV-stabilised virgin polyethylene float section, tower assembly, top marks and panelling. 316-grade stainless steel fixtures.
Wall Thickness (mm/inches)	18 / $\frac{3}{4}$	18 / $\frac{3}{4}$
Ballast (kg/lbs)	672 / 1482 external steel	672 / 1482 external steel
Filling	Closed-cell polyurethane foam (float section)	Closed-cell polyurethane foam (float section)
Height (mm/inches)	6240 / 245 $\frac{5}{8}$	6240 / 245 $\frac{5}{8}$
Width (mm/inches)	2600 / 102 $\frac{3}{8}$	2600 / 102 $\frac{3}{8}$
Mass (kg/lbs)	2340 / 5159 (depending on payload)	2340 / 5159 (depending on payload)
Radar Reflector	Echomax EM230	Echomax EM230
Product Life Expectancy	>20 years ^	>20 years ^
Certifications		
IALA	Surface colours compliant to IALA E-108	Surface colours compliant to IALA E-108
Quality Assurance	ISO9001:2015	ISO9001:2015
Intellectual Property		
Trademarks	SEALITE® is a registered trademark of Sealite Pty Ltd	SEALITE® is a registered trademark of Sealite Pty Ltd
Warranty *	5 years	5 years
Lantern Options	Sealite SL-C310, SL-C410, SL-C415, SL-C420, SL-C500, SL-C600, SL-125 Series or SL-155 Series	Sealite SL-C310, SL-C410, SL-C415, SL-C420, SL-C500, SL-C600, SL-125 Series or SL-155 Series
Options Available	<ul style="list-style-type: none"> · Custom signage · Day marks · Monitoring Systems (AIS, GSM) · Name Plate · Aluminium Tower Assembly · Galvanised or stainless steel mooring post · Tail tube mooring post 	<ul style="list-style-type: none"> · Custom signage · Day marks · Monitoring Systems (AIS, GSM) · Name Plate · Aluminium Tower Assembly · Galvanised or stainless steel mooring post · Tail tube mooring post

* Intensity setting subject to solar availability

* Subject to standard terms and conditions

* Specifications subject to change or variation without notice
^ Refer to the Sealite website under the warranty section



We believe technology improves navigation™



Sealite Pty Ltd
Australia
☎ +61 (0)3 5977 6128

Sealite Asia Pte Ltd
Singapore
☎ +65 6908 2917

Sealite United Kingdom Ltd
UK
☎ +44 (0) 1502 588026

Sealite USA LLC
USA
☎ +1 (603) 737 1311



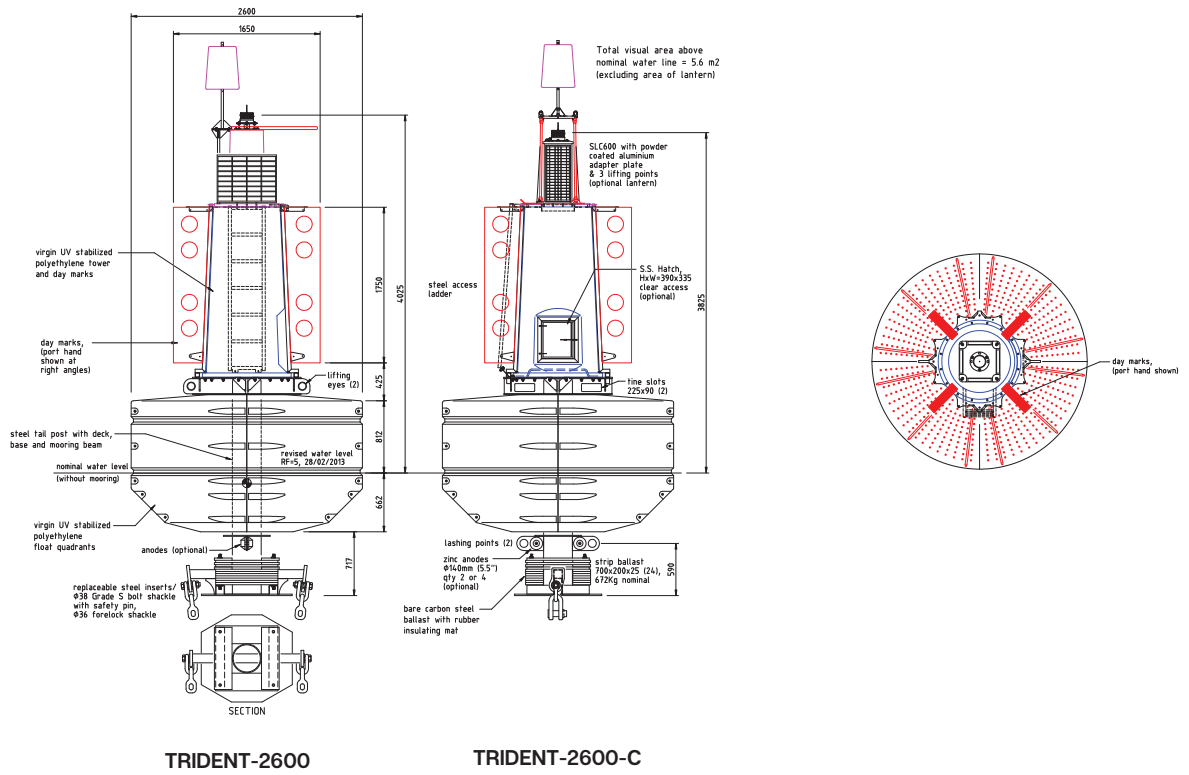

Specifications subject to change or variation without notice
 Refer to the Sealite website under the warranty section
 CE
 Subject to standard terms and conditions
 Intensity setting subject to solar availability

We believe technology improves navigation™



Sealite Pty Ltd
 Australia
 +61 (0)3 5977 6128

Sealite Asia Pte Ltd
 Singapore
 +65 6908 2917

Sealite United Kingdom Ltd
 UK
 +44 (0) 1502 588026

Sealite USA LLC
 USA
 +1 (603) 737 1311

