

Solar Aviation Light

AV-70 and AV-70-HI

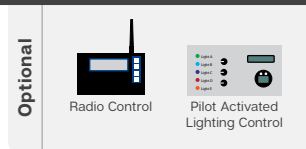

The solar powered AV-70 is a field proven aviation light that offers enormous benefits over traditional battery and hard-wired aviation lights including low maintenance and no underground wiring.

These completely self-contained LED lights are designed to suit a range of aviation and general applications including emergency airstrip, caution, taxiway, and threshold lighting.

The unit has two high-performance solar modules mounted within the lens, which maximize solar collection and provide reliable operation in a range of environmental conditions.

The focal plane of the light is designed to provide a vertical divergence of between 0 to +7 degrees, and the user-replaceable battery ensures a service life of up to 12 years.

AV-70

The AV-70 is made from tough, durable UV stabilized LEXAN® polycarbonate, and incorporates an internal photodiode for automatic night activation once the ambient light threshold drops sufficiently.

Completely self-contained and able to be installed in minutes, the AV-70 is the preferred choice for marking of indigenous, regional and mining airstrips around Australia, and remote airfields globally.

AV-70-HI

The AV-70-HI is a high intensity version of the popular AV-70 and is ideal for use in high sunlight areas.

Optional Radio Control

The AV-70-RF is a radio-controlled version of the popular AV-70, which can be used in conjunction with a PALC or simple handheld controller. Users can wirelessly control ON/OFF functions, adjust light intensities or switch between visual and IR (tactical) operational modes if fitted.

Cost Effective

- Solar Powered
- No running costs
- Low ongoing maintenance costs

Easy Install

- No trenching of cables
- No mains power

Reliable

- No bulbs blown – ever
- Latest LED technology
- No Moving parts

High Performance

- Fully integratable into an Avlite runway lighting system
- Dusk-to-dawn or on demand operation

Optional Add Ons

- Infrared Output
- Radio Control
- Mounting Solutions

Applications

- ICAO and FAA Compliant
- Runway threshold/end
- Runway Edge Light
- Taxiway Edge Light

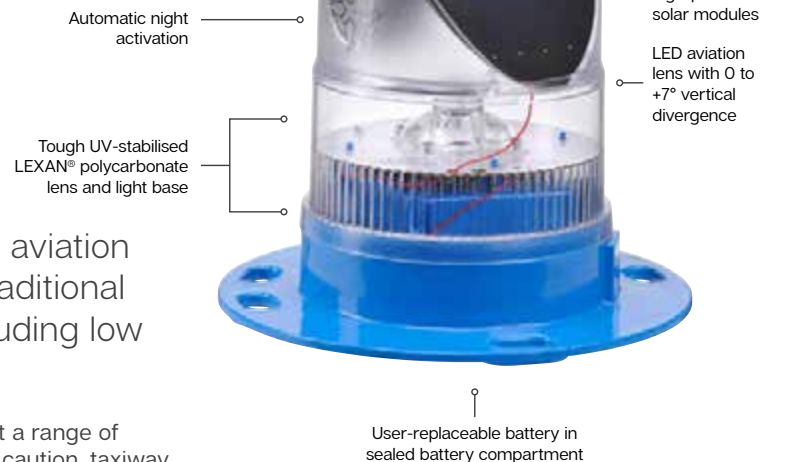

Technical Specifications *

	AV-70	AV-70-HI
Light Characteristics		
Light Source	LED	LED
Available colors	Red, Green, White, Amber, Blue	Red, Green, White, Amber, Blue
Horizontal Output (degrees)	360	360
Vertical Divergence (degrees)	0 to +7	0 to +7
Intensity Adjustments	3 Steps - Low, Med, High †	3 Steps - Low, Med, High †
LED Life Expectancy (hours)	>100,000	>100,000
Electrical Characteristics		
Operating Voltage (V)	3.6	3.6
Temperature Range	-40 to 55°C	-40 to 55°C
Solar Characteristics		
Solar Module Type	Monocrystalline	Monocrystalline
Output (watts)	2.8 (2 x 1.4 watt)	2.8 (2 x 1.4 watt)
Solar Module Efficiency (%)	21	21
Charging Regulation	Microprocessor controlled	Microprocessor controlled
Power Supply		
Battery Type	High grade NiMH – Environmentally friendly	High grade NiMH – Environmentally friendly
Battery Capacity (Ah)	8.6	17.2
Nominal Voltage (V)	3.6	3.6
Autonomy (nights)	Steady-on: >14	Steady-on: >19
Radio Control		
Frequency	2.4GHz ISM Band	2.4GHz ISM Band
Range	Up to 1.4km relayed	Up to 1.4km relayed
Expandability	AvMesh®	AvMesh®
Compliance	FCC / CE	FCC / CE
Physical Characteristics		
Body Material	LEXAN® Polycarbonate – UV stabilized	LEXAN® Polycarbonate – UV stabilized
Lens Material	LEXAN® Polycarbonate – UV stabilized	LEXAN® Polycarbonate – UV stabilized
Lens Diameter (mm/inches)	140 / 5½	140 / 5½
Lens Design	Single LED optic	Single LED optic
Mounting	6 x 17mm holes on 200mm PCD	6 x 17mm holes on 200mm PCD
Height (mm/inches)	240 / 9½	240 / 9½
Width (mm/inches)	231 / 7¾	231 / 7¾
Mass (kg/lbs)	1.4 / 3¼	1.6 / 3½
Product Life Expectancy	Up to 12 years	Up to 12 years
Environmental Factors		
Humidity	0 to 100%, MIL-STD-810F	0 to 100%, MIL-STD-810F
Icing	22kg per square inch	22kg per square inch
Wind Speed	Up to 160kph	Up to 160kph
Shock	MIL-STD-202G, Test Condition G, Method 213B	MIL-STD-202G, Test Condition G, Method 213B
Vibration	MIL-STD202G, Test Condition B, Method 204	MIL-STD202G, Test Condition B, Method 204
Certifications		
CE	EN61000-6-3:2007 EN61000-6-1:2007	EN61000-6-3:2007 EN61000-6-1:2007
Quality Assurance	ISO9001:2015	ISO9001:2015
Waterproof	IP68	IP68
Regulation	DGAC (Mexico)	DGAC (Mexico)
Compliance		
ICAO	Annex. 14 Volume 1 'Aerodrome Design and Operations'	Annex. 14 Volume 1 'Aerodrome Design and Operations'
FAA	L861T	L861T
FAA	Barricade AC 150/5370-2F	Barricade AC 150/5370-2F
FAA	LED Colour Standard (Engineering Brief No. 67D)	LED Colour Standard (Engineering Brief No. 67D)
Regulation		CASA MOS Part 139, Volume 2, 2016, Section 9.13.15
Intellectual Property		
Trademarks	AVLITE® is a registered trademark of Avlite Systems	AVLITE® is a registered trademark of Avlite Systems
Warranty *	3 year warranty	3 year warranty
Options Available	<ul style="list-style-type: none"> Manual Operation Radio Controlled Avlite Pilot Activated Lighting Control IR LEDs External ON/OFF Switch External Battery Charging Port Solar Booster™ 	<ul style="list-style-type: none"> Manual Operation Radio Controlled Avlite Pilot Activated Lighting Control IR LEDs External ON/OFF Switch External Battery Charging Port Solar Booster™

Technical Illustration

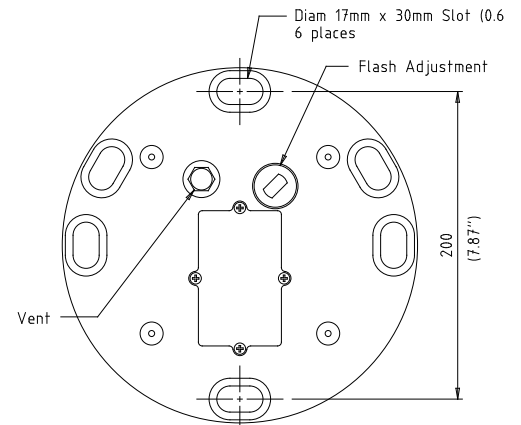
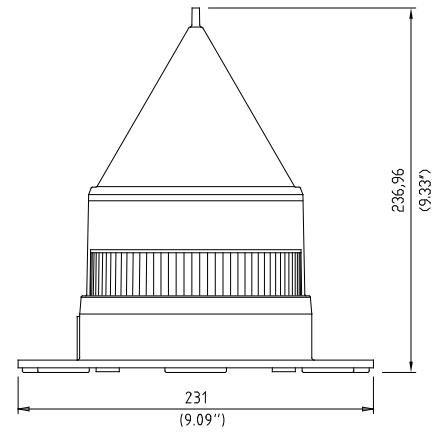

Photometric Output

AV-70 Steady ON

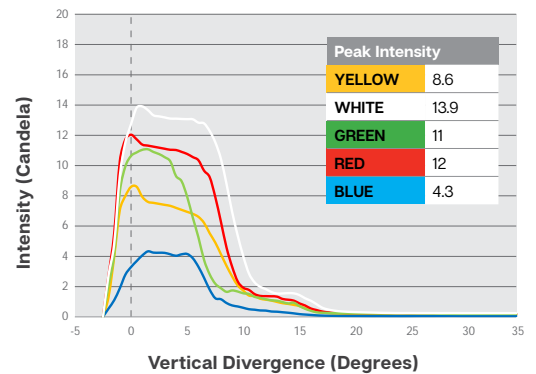

AV-70-HI Steady ON

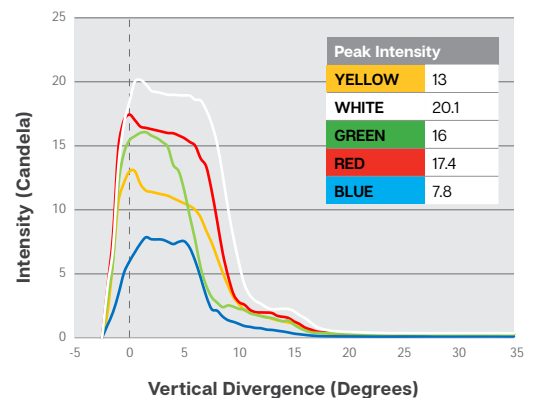

• Specifications subject to change or variation without notice
 * Subject to standard terms and conditions
 † Intensity setting subject to solar availability

